

November 1998

doc.: IEEE 802.11-98/385

The Short Preamble for 802.11 2.4 GHz WLANs

Carl Andren
Harris
Semiconductor

Submission

Slide 1

Carl Andren, Harris Semiconductor

November 1998

doc.: IEEE 802.11-98/385

Summary

- A long preamble will allow both interoperability and co-existence with low rate LANs
- A short preamble will allow better throughput when the LAN does not need to contend with low rate PHYs.
- The preamble length has been designed to allow for AGC settling, antenna diversity selection, and equalizer training

Submission

Slide 2

Carl Andren, Harris Semiconductor

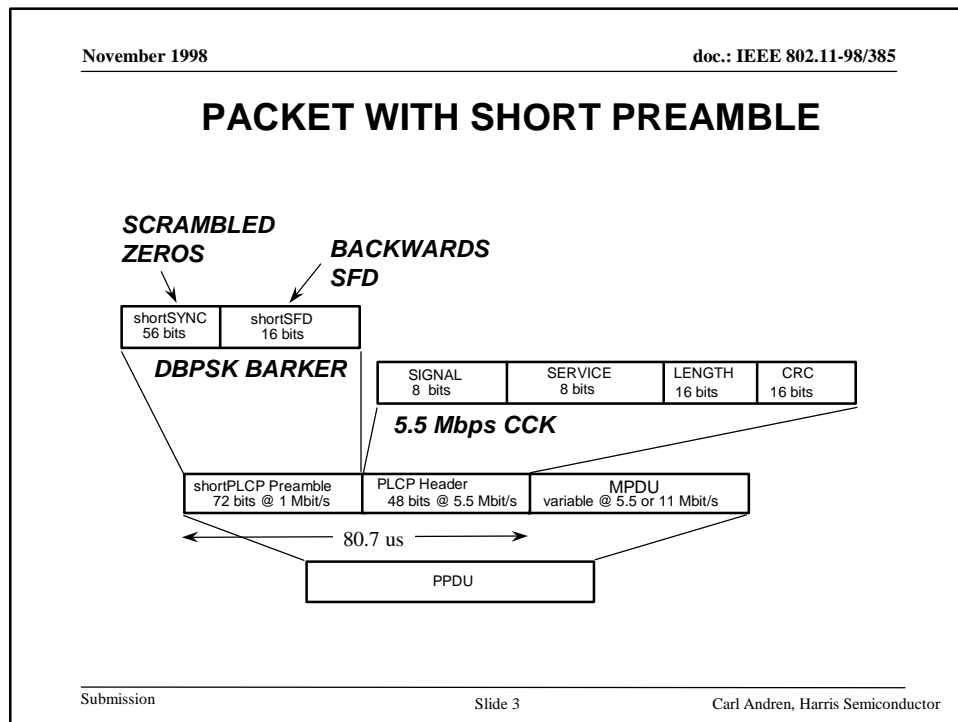

November 1998 doc.: IEEE 802.11-98/385

The Alantro Proposal

- Alantro proposes to modulate the header portion of the short preamble with 2 MBps instead of 5.5 MBps CCK.
 - This makes the E_s/N_0 more of a match to PBCC coding, helping their option
 - What this does is extend the length of the overhead by 16 us to 96 us, hurting throughput.
 - It does allow the equalizer training more time
- Harris/Lucent feels this is unnecessary for our approach

Submission Slide 4 Carl Andren, Harris Semiconductor

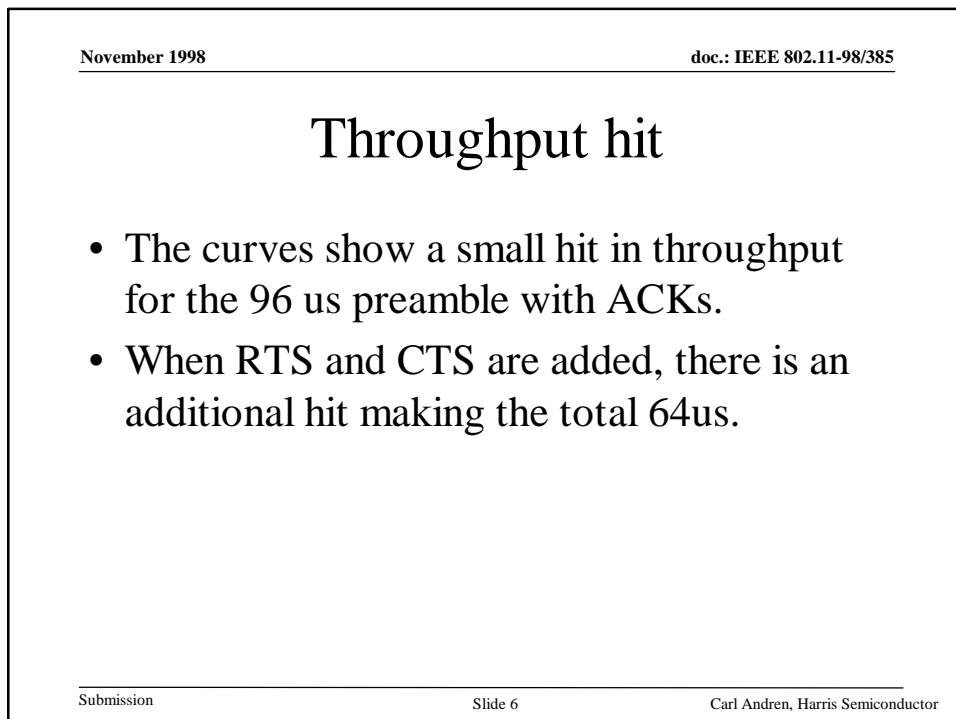
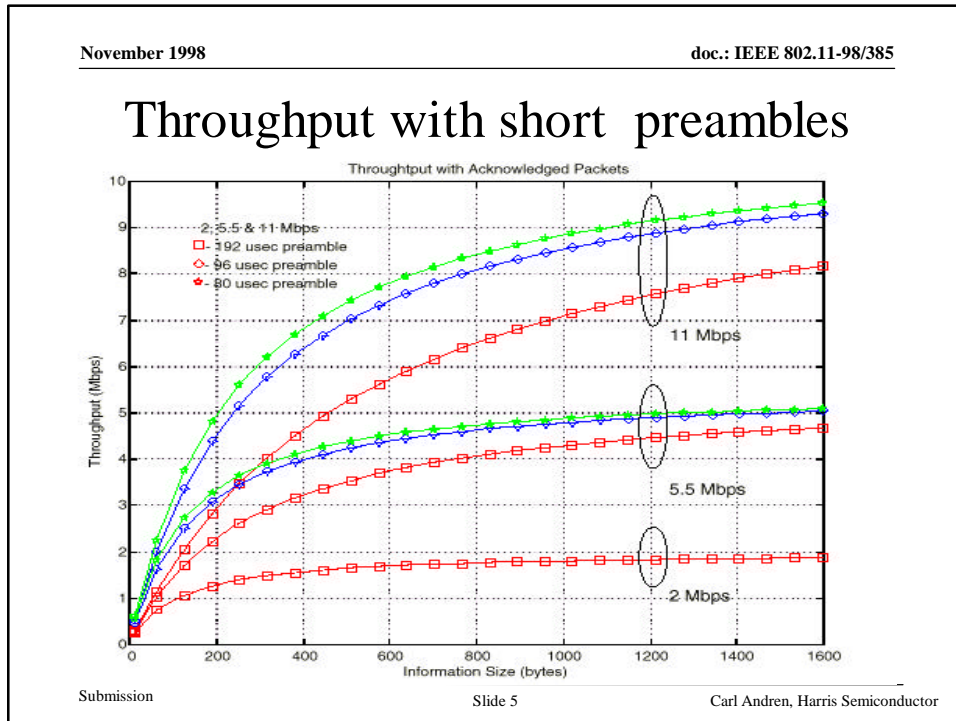

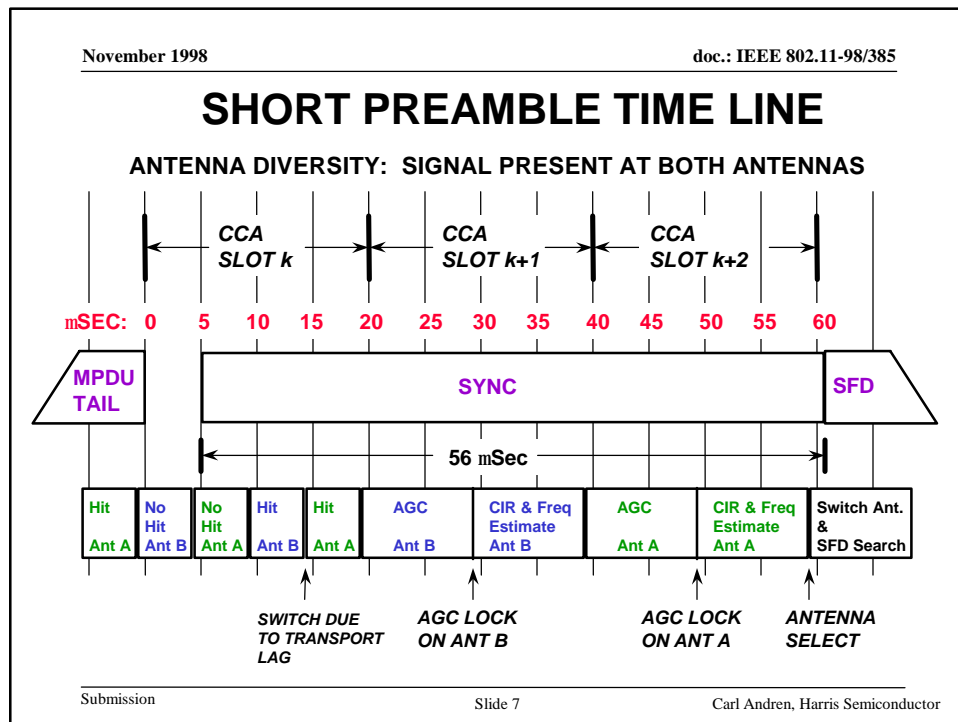

Timeline Considerations

- As you can see from the slide, the time line is tight, so a shorter sync field is not acceptable
- Antenna selection must occur enough before the SFD comes along to allow descrambler seeding
- Not all of the SFD has to be used if the SNR is high enough
- AGC settling takes 10 us and the AGC is locked down during the packet to keep it from thwarting the equalizer

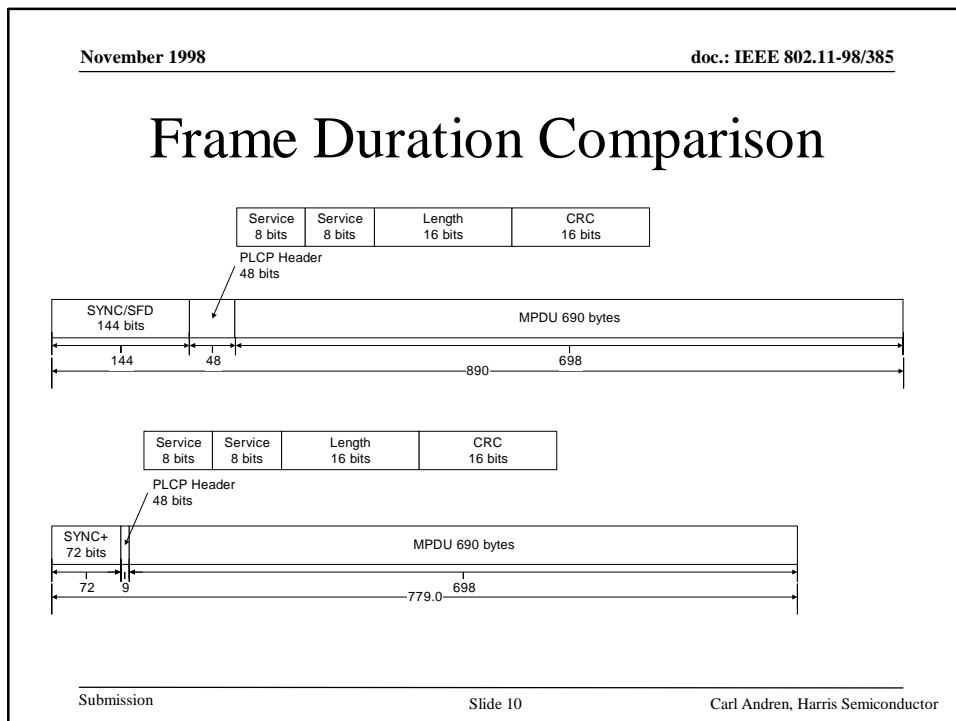
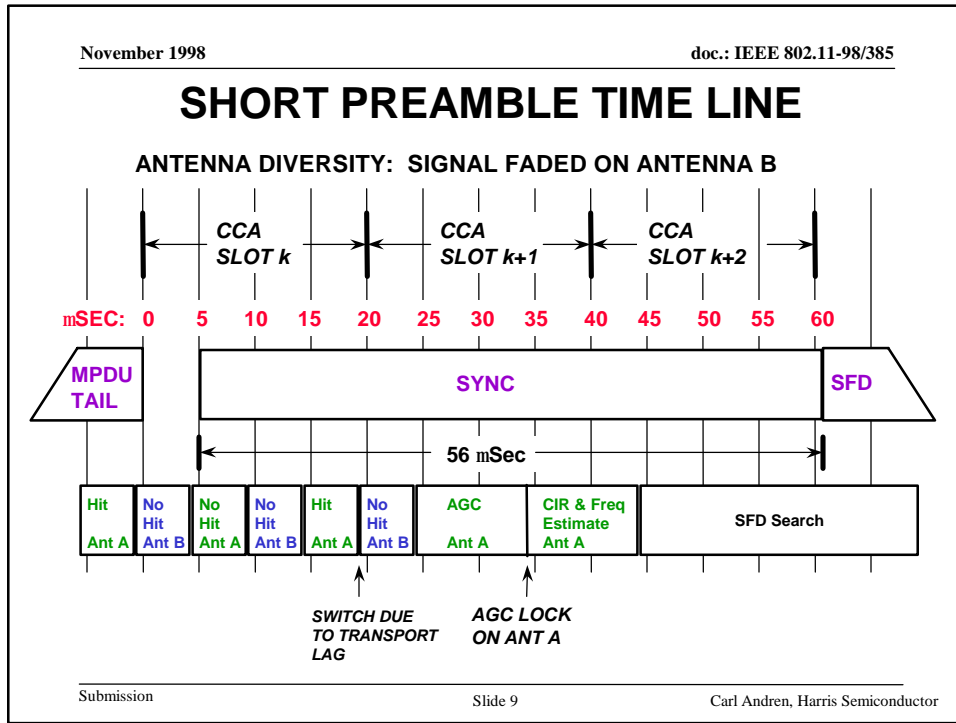

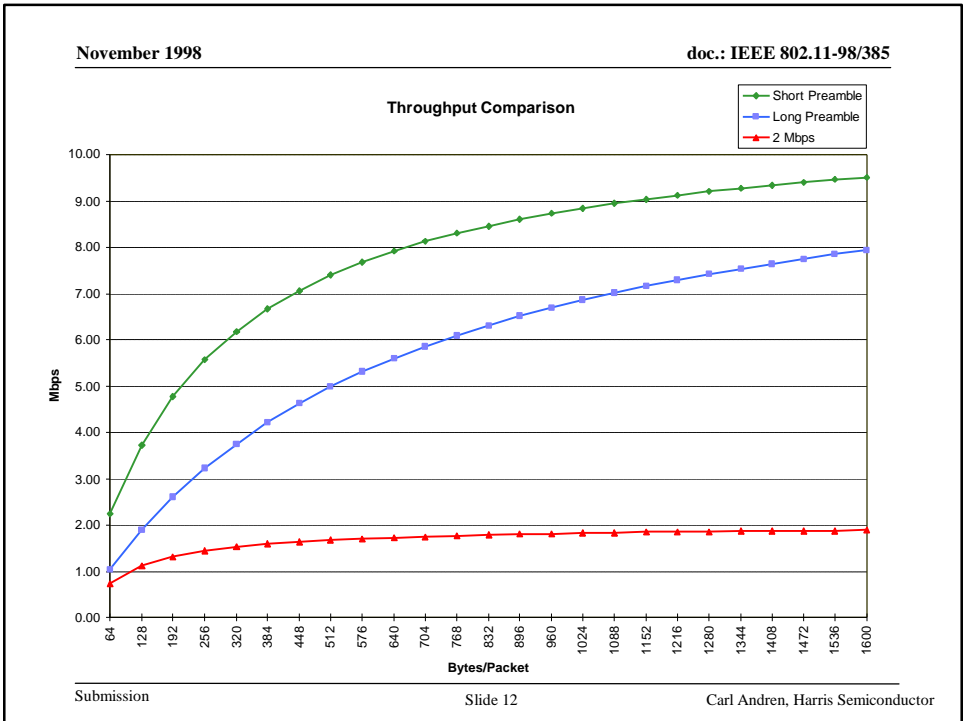
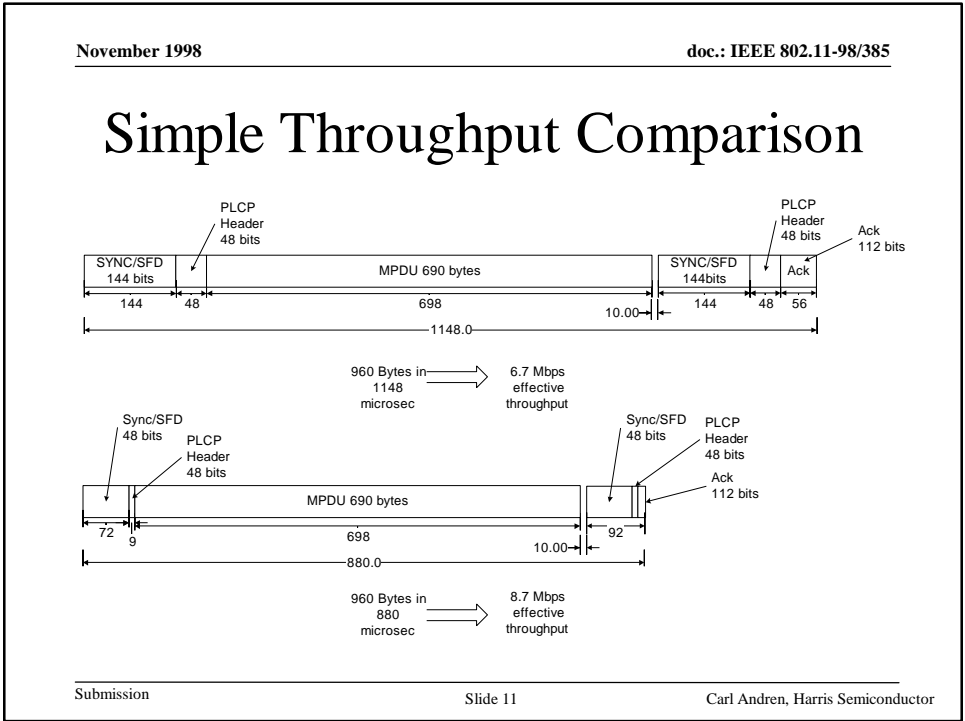

RTS CTS Effect on Throughput

- 802.11 has the advantage of utilizing the RTS/CTS mechanism to reduce collisions due to hidden nodes (virtual carrier sense)
- The extra transaction on each packet reduces the overall throughput
- Adding 16 us more to each preamble costs 4 times that much for the whole transaction

Effective Throughput with RTS/CTS

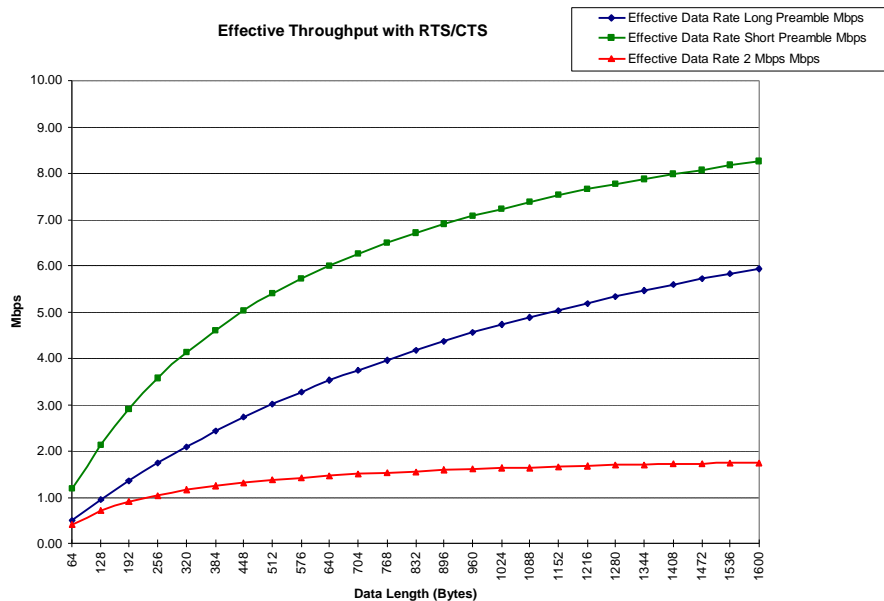

Comparison with Loading

- Simulates the effect of back-off's on the throughput with short and long preamble
- Effect of preamble length is less pronounced with increasing load

Comparison of Throughput with Loading

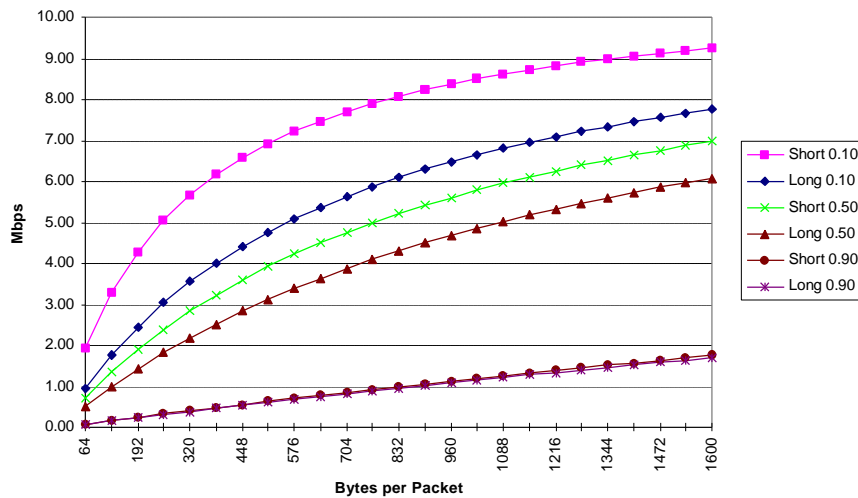

November 1998

doc.: IEEE 802.11-98/385

CCA mechanism and Co-Channel signal detection time

- Measure the correlated signal energy in the preamble over 5 us dwells beginning when the receiver is enabled and compare that to a threshold
- The detection time is less than the slot time by enough to include diversity
- FH detection is done on clock energy in similar dwells.

Submission

Slide 17

Carl Andren, Harris Semiconductor

November 1998

doc.: IEEE 802.11-98/385

Interoperability

- The CCK receiver can recognize both long and short preambles. If the CCK receiver detects a short preamble it trains on the short. If the receiver detects the long preamble it trains on the long preamble. This allows the receiver to better process the channel impulse response.
- **Scenario:** CCK starts with a short preamble. Legacy DSSS modems defer on that preamble. It is normally received by the CCK modems that have the option to receive a short preamble. The CCK modem can receive both CCK (short and long) and legacy DSSS transmissions. If reception is poor (or there is, for whatever reason, a coexistence problem with IEEE modems), the transmitter falls back to 5.5 Mbit/s or to the long preamble. The long preamble is also recognized by the legacy DSSS only modems, making use of the IEEE imbedded multi-rate capability.
- **Result:** CCK modems send, if circumstances allow, the short preamble, making full use of the higher throughput capabilities. They are at all times interoperable with legacy DSSS modems, recognizing the long preamble, receiving (and sending) at the low rates. If there are coexistence problems the CCK modems falls back to the long preamble.

Submission

Slide 18

Carl Andren, Harris Semiconductor

November 1998

doc.: IEEE 802.11-98/385

Coexistence

- **Low rate and high rate PHYs will coexist within the same network.**
- **Short preambles will be used only within networks of exclusively high rate capable PHYs**
- **Short and long preambles may be intermingled on the same network as long as all PHYs are high rate capable and the MAC software is configured to allow mingling.**
- **All (rate) PHYs will perform CCA on either long or short preambles**
- **Performing CCA in the middle of a packet on CCK is problematic.**

Submission

Slide 19

Carl Andren, Harris Semiconductor

November 1998

doc.: IEEE 802.11-98/385

Coexistence Philosophy

- **Coexistence means that short preamble CCK defers for legacy DSSS (and long CCK) and vice versa.**
- **legacy DSSS Receiver**
 - detects short preamble (carrier or energy); CCA reports channel busy;
 - waits for Start frame delimiter but will not find it.
 - It is not prescribed in the standard what action the receiver has to take, there are several possibilities:
 - once the CCK signal starts after the preamble, the receiver will lose code lock and cause CCA to go to the channel IDLE state. The receiver returns to the RX idle state and starts looking for a carrier, which it does not see (because of CCK). This might result in a collision or the receiver being out of slot sync.
 - The receiver times out on the SFD. This also leads to out of sync and possible collision
 - CCA reports channel busy until the ED drop of the CCK signal. In this case the DSSS receiver stays in slot sync.
 - It is clear that the third implementation (ED) is the best guaranty for coexistence.

Submission

Slide 20

Carl Andren, Harris Semiconductor

Coexistence Philosophy

- CCK receiver
 - configured to process a short preamble, the receiver will also detect the long preamble and process the legacy DSSS frame. The CCK receiver can see the legacy transmitter CS in the middle of a message and defer if necessary.
 - On the CCK portion of the packet, the CCK receiver also loses the CS if it is based on Barker correlation and will not behave properly in a network. Therefore, it too could perform better if it had an improved CCA measure like an ED that works or a time out feature.